

# PYLE<sup>®</sup> PRO

## PYD2200/2300U 5 channel professional mixer

OWNER'S  
MANUAL



owner's manual

## **IMPORTANT SAFETY INSTRUCTIONS**

1. **Read Instructions** — All the safety and operating instructions should be read before the appliance is operated.
2. **Retain Instructions** — The safety and operating instructions should be retained for future reference.
3. **Heed Warnings** — All warnings on the appliance and in the operating instructions should be adhered to.
4. **Follow Instructions** — All operating and use instructions should be followed.
5. **Water and Moisture** — The appliance should not be used near water -for example, near a bathtub, washbowl, kitchen sink, laundry tub, swimming pool, or a wet basement.
6. **Ventilation** — The appliance should be situated so that its location or position does not interfere with its proper ventilation. For example, the appliance should not be situated on a bed, sofa, rug, or similar surface that may block the ventilation openings: or placed in a built-in installation, such as a bookcase or cabinet that may impede the flow of air through the ventilation openings.
7. **Heat** — The appliance should be situated away from heat sources such as radiators, heat registers, stoves, or other appliances (including amplifiers) that produce heat.
8. **Power Sources** — The appliance should be connected to a power supply only of the type described in the operating instructions or as marked on the appliance.
9. **Grounding or Polarization** — Precaution should be taken to insure that the grounding or polarization means of an appliance is not defeated.
10. **Power-Cord Protection** — Power supply cords should be routed so that they are not likely to be walked on or pinched by items placed upon or against them, paying particular attention to cords at plugs, convenience receptacles, and the point at which they exit from the appliance.
11. **Cleaning** — The appliance should be cleaned only as recommended by the manufacturer.
12. **Power Lines** — An outside antenna system should not be located in the vicinity of overhead power lines or other electric light or power circuits, or where it can fall into such power lines or circuits. When installing an outside antenna system, extreme care should be taken to keep from touching such power lines or circuits as contact with them might be fatal.
13. **Nonuse Periods** — The power cord of the appliance should be unplugged from the outlet when the appliance is to be left unused for a long period of time.
14. **Object and Liquid Entry** — Care should be taken so that objects do not fall and liquids are not spilled into the enclosure through openings.
15. **Carts and Stands** — If the appliance is used with a cart or stand, the cart or stand should be a type recommended by the manufacturer.  
An appliance and cart combination should be moved with care. Quick stops, excessive force, and uneven surfaces cause the appliance and cart combination to overturn.
16. **Mounting** — The appliance should be mounted only as recommended by the manufacturer.
17. **Damage Requiring Service** — The appliance should be serviced by qualified service personnel when:
  - A. The power-supply cord or plug has been damaged.
  - B. Objects have fallen into, or liquid has been spilled into the appliance enclosure.
  - C. The appliance has been exposed to rain.
  - D. The appliance has been dropped, or the enclosure damaged.
  - E. The appliance does not appear to operate normally or exhibits a marked change in performance.
18. **Servicing** — The user should not attempt to service the appliance beyond that described in the user's operating instructions. All other servicing should be referred to qualified personnel.
19. **Overloading** — Do not overload wall outlets and extension cords as this can result in a risk of fire or electric shock.
20. **Replacement Parts** — When replacement parts are required, be sure the service technician has used replacement parts specified by the manufacturer or have the same characteristics as the original part. Unauthorized substitutions may result in fire, electric shock or other hazards.
21. **Safety Check** — Upon completion of any service or repairs to this appliance, ask the service technician to perform safety checks to determine that the appliance is in proper operating condition.



<p><b>WARNING:</b> To reduce the risk of fire or shock hazard, do not expose this product to rain or moisture.</p>	<p>This symbol is intended to alert you to the presence of un-insulated dangerous voltage within the products enclosure that might be of sufficient magnitude to constitute a risk of electric shock. Do not open the products case.</p>
<div style="display: inline-block; text-align: center; background-color: black; color: white; padding: 2px 10px; font-weight: bold; margin: 0 10px;"> <b>CAUTION</b>  <b>RISK OF ELECTRIC SHOCK</b>  <b>DO NOT OPEN</b> </div>	<p>This symbol is intended to inform you that important operating and maintenance instructions are included in the literature accompanying this product.</p>
<p><b>CAUTION:</b> To reduce the risk of electric shock, do not remove cover or back. No user-serviceable parts inside. Refer servicing to qualified personnel.</p>	

## Your PYLE PRO Series Performance Mixer

is a sophisticated control center, perfect for mixing sound from multiple playback sources such as microphones tuners, CD players, turntables or the audio outputs from a VCR. This mixer is ruggedly constructed for home or professional use. Wide range volume controls, permit you to adjust sound levels accurately to achieve just the right mix for playing through your speakers system or for recording.

Please read this manual thoroughly before you attempt to set up and use the mixer. It contains a range of suggestions and instructions to insure safe usage. Set up and used properly, you can expect years of trouble-free service from this product.

## Input/Output Features

### PYD2200

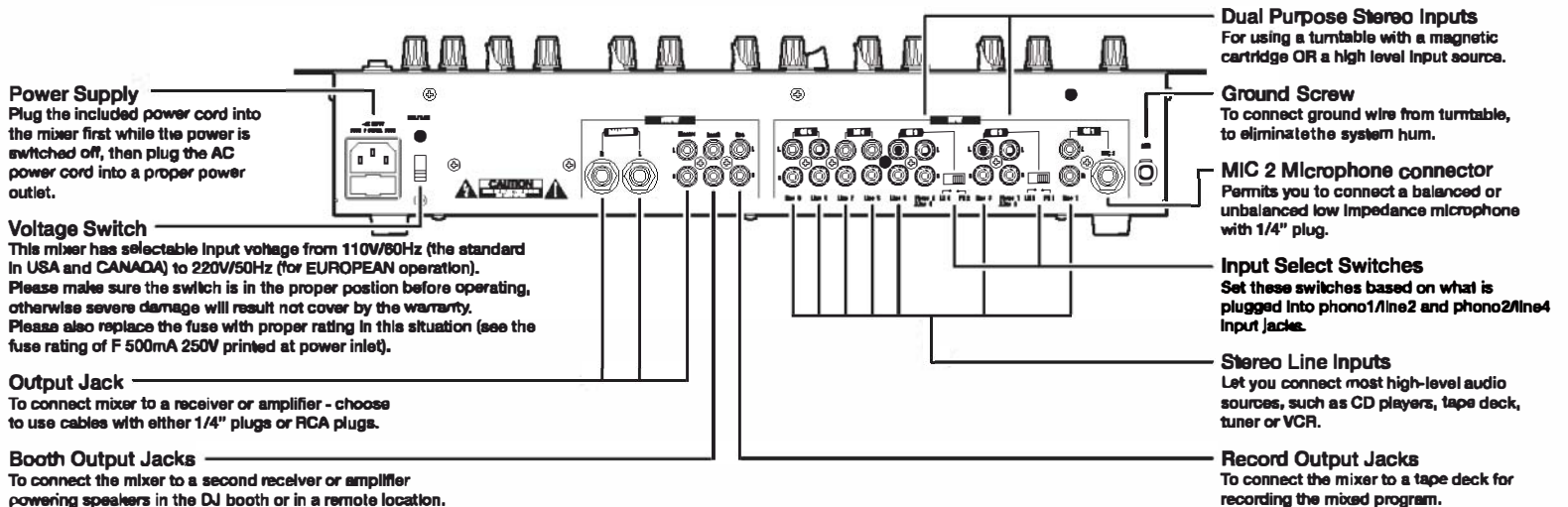

### PYD2300U

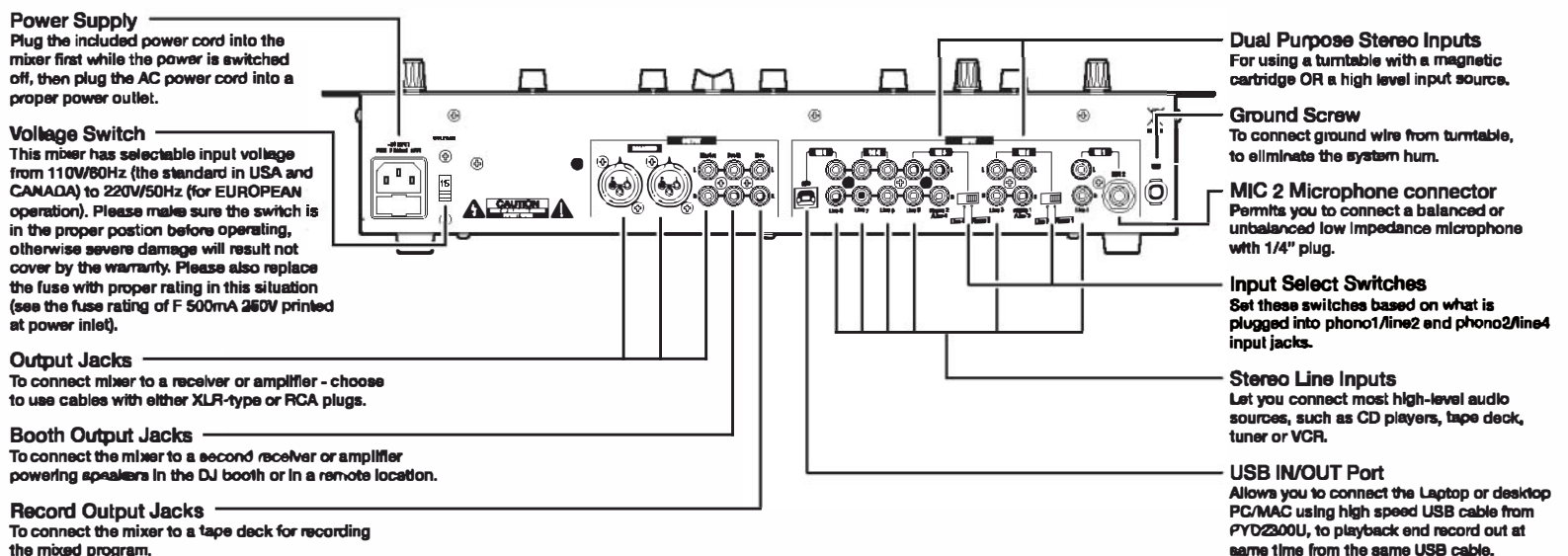

## PYD2200

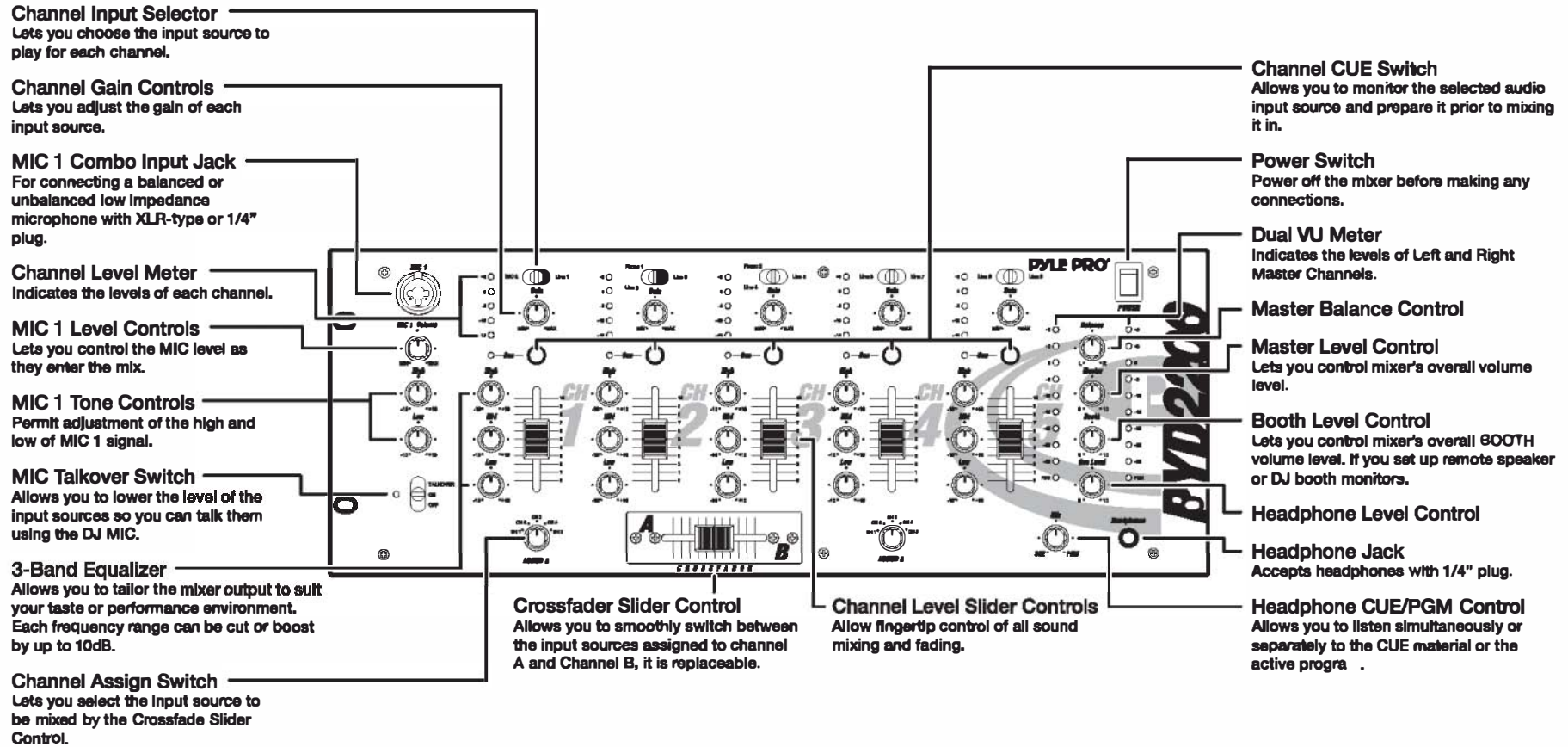

# PYD2300U

## Features and Controls:

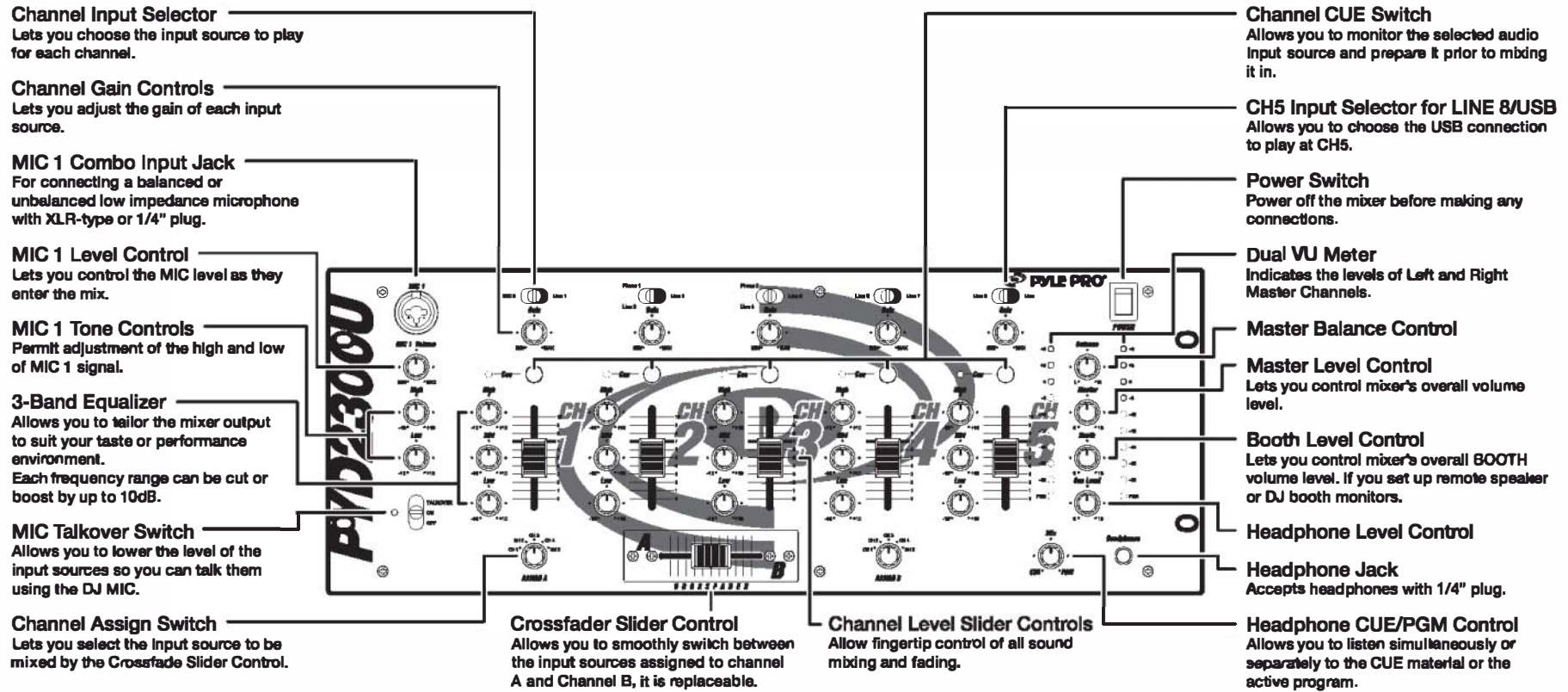

### USB OPERATION:

The input selection at CH5 allows you to choose the USB connection to play at CH5.

### ON PC

1. Turn on the computer and PYD2300U
2. Connect USB cable from port of mixer to your computer.
3. The window will recognize the mixer as a "USB AUDIO DEVICE" or "USB AUDIO CODEC", and install any required system components. automatically.
4. Open the START menu and go to CONTROL PANEL, click on the SOUND AND AUDIO DEVICES ICON, to change system audio preferences in Window.
5. Click on the AUDIO tab, to access audio device settings.
6. Choose the USB AUDIO CODEC as a DEFAULT DEVICE.
7. Click on APPLY and you are ready to use the PYD2300U with your PC.

### ON MAC

1. Turn on the computer and PYD2300U
2. Connect USB cable from port of mixer to your computer.
3. Open SYSTEM PREFERENCES under APPLE menu.
4. Choose the SOUND icon in SYSTEM PREFERENCES.
5. Choose the OUTPUT tab in the SOUND window.
6. Select USB AUDION CODEC under CHOOSE A DEVICE FOR SOUND OUTPUT.
7. Repeat the procedure for the INPUT tab and you are ready to use PYD2300U with your MAC.

# Connection Diagram:

## PYD2200

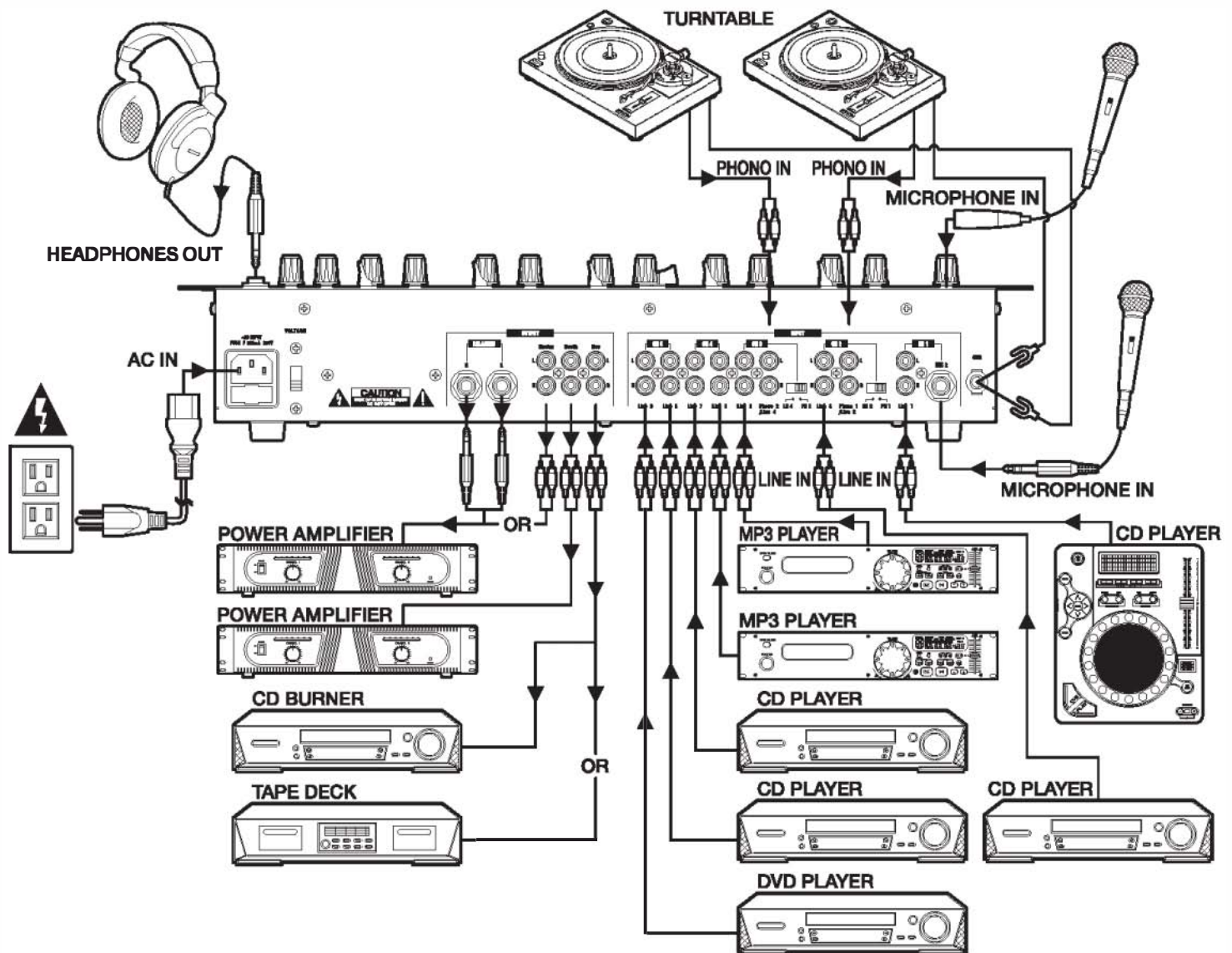

This mixer permits connection of up to eleven (11) audio input sources, including two microphones. Such a system might include, for examples:

Two Microphones  
Two Turntables  
Seven CD Players

Two Microphones  
Nine CD Players

Two Microphones  
Two Turntables  
Four CD Players  
Three Cassette Decks

# Connection Diagram:

## PYD2300U

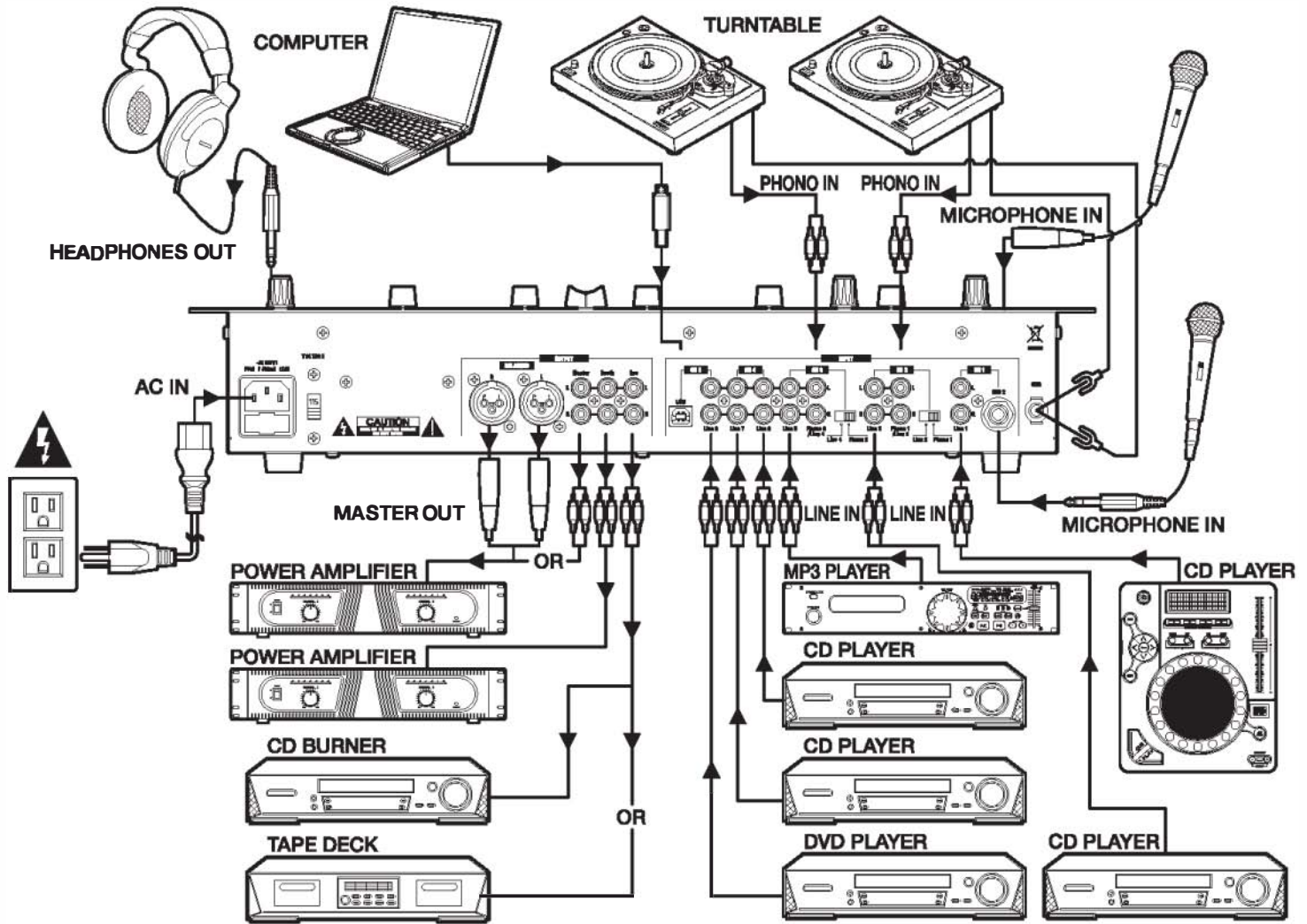

▼ Please complete warranty card, detach and return ▼

This mixer permits connection of up to eleven (11) audio input sources, including two microphones. Such a system might include, for examples:

Two Microphones  
Two Turntables  
Six CD Players  
One USB Port

Two Microphones  
Eight CD Players  
One USB Port

Two Microphones  
Two Turntables  
Three CD Players  
Three Cassette Decks  
One USB Port

\_\_\_\_\_

\_\_\_\_\_

\_\_\_\_\_

Place  
Stamp  
Here

**PYLE**<sup>®</sup>  
**PYLE PRO**  
 PYLE PRO Audio, Inc.  
 1600 63rd Street  
 Brooklyn, NY 11204

# Specifications

## PYD2200/2300U

### Input Sensitivity/Impedance

MIC ..... 1.5 mV/600 Ohms Balanced  
Phono 1-2 ..... 3.0mV/50K Ohms  
Line ..... 150 mV/27K Ohms

### Output Level

Master ..... 2.0 V/10K Ohms  
Booth ..... 2.0 V/10K Ohms  
Record ..... 150 mV/10K Ohms

Frequency Response .... 20Hz - 20kHz +/- 3 dB

### S/N Ratio (at 1 kHz)

Mic ..... 60 dB/1.5mV input  
Phono ..... 70 dB/3.0mV input  
Line ..... 80 dB/150.0mV input

### Distortion

Mic ..... 0.20%  
Phono ..... 0.05%  
Line ..... 0.03%

### Tone Control

Treble ..... 10kHz; +10/-10dB  
Mid ..... 1 KHz; +10/-10dB  
Bass ..... 100Hz; +10/-10dB

### MIC Tone Control

High ..... 10 kHz; +10/-10dB  
Low ..... 100Hz; +10/-10dB

Talkover Attenuation .. -16dB

Power Source ..... 120 VAC,60Hz/230 VAC,50Hz

### Dimensions, inches (mm)

WxHxD ..... 19 x 3 x 7 (482 x 76.8 x 178)

### Weight, lbs (kg)

PYD2200.....8.44 (3.83)  
PYD2300U.....8.64 (3.92)

**Specifications are typical; individual units might vary.  
Specifications are subject to change and improvement without notice.**

#### Limited Warranty

All PYLE PRO products are carefully constructed and tested before shipment. Units purchased in the USA are warranted to be free of defects in material and workmanship for one (1) year from the date of purchase. This warranty is limited to the original retail purchaser of the mixer.

Should the unit fail due to factory defects in material or workmanship, your unit will be repaired or replaced at the sole discretion of PYLE.

To obtain warranty service, you must first call our Consumer Return Hotline at (718) 236-6948 to obtain a Return Authorization Number. This R.A. # must appear on the outside of your package and on all paperwork relating to your return.

When returning the unit to us for warranty service, it must be carefully packed and shipped, prepaid, to:

R.A.#: \_\_\_\_\_  
PYLE PRO Service Center  
1600 63rd Street  
Brooklyn, NY 11204

You must also include the following items with your return:

- A copy of your sales receipt or other proof of purchase
- A brief letter, indicating the problem you are experiencing with the product
- Include in your letter your return address, daytime phone number and R.A. number
- Also include a check or money order for \$20.00 for return shipping, handling and insurance, or provide your Visa/MC number with expiration date.

Our obligation under this warranty is limited to the repair or replacement of the defective unit when it is returned to us prepaid. This warranty will be considered void if the unit was tampered with, improperly serviced or subject to misuse, neglect or accidental damage.

▼ Please complete warranty card, detach and return ▼

Thank you for purchasing this PYLE product. To activate your warranty, please mail this card within 10 days.

warranty registration card

PYLE PRO MIXERS

Name \_\_\_\_\_

Address \_\_\_\_\_

City, State ZIP \_\_\_\_\_

Model No. \_\_\_\_\_

Serial # (if available) \_\_\_\_\_

Date of Purchase \_\_\_\_\_

#### Purchased at:

- Music Products Store       Sound Contractor/Installer       Mail Order  
 Catalog Merchandiser       Other \_\_\_\_\_

[www.pyleaudio.com](http://www.pyleaudio.com)

7 - Pyle Pro Mixer PYD2200/2300U  
Owner's Manual